



b2match.com/blight

Implementation Manual

“B Light Scheme”

(Fostering value added business cooperation between SMEs operating on different sides of the Hungary-Croatia border)

to be implemented under Priority 1 of
Interreg V-A Hungary-Croatia Co-operation Programme 2014-2020

Service contract No. 143ST-2015HR

Contracting Authority:

Széchenyi Programme Office Consulting and Service Nonprofit Ltd. (1053 Budapest, Szép u. 2.)

Consultants:

- Logframe Tanácsadó Iroda Kft. (consortium leader)
- ICG Ex Ante Tanácsadó Iroda Kft.
- Vitál Pro Kft.



This document has been produced with the financial assistance of the European Union. The content of the document is the sole responsibility of Croatian agency for SMEs, Innovations and Investments (HAMAG-BICRO) and can under no circumstances be regarded as reflecting the position of the European Union and/or the Managing Authority.

Contract context

Service contract was signed on 30 October 2015. Aim of the contract is to provide technical assistance to the Contracting Authority and the Managing Authority of the Interreg V-A Hungary-Croatia Cross-border Cooperation Programme in preparation of the B Light Scheme to be implemented under Priority 1 of the Programme.

Selection of Thematic Objective (TO) 3 to be Priority 1 of the Cooperation Programme was justified by low level of SME density, low absorption capacity of mainstream SME funding in the border area that is suffering from structural problems and low level of internationalisation. Main result indicator of the priority is to generate gross value added in the industry and services sector. Implementation of the Priority would base on an SME grant scheme facility towards SMEs in the programme area undertaking cross-border cooperation activities. Management of the B Light Scheme would be carried out by a group of intermediary SME development bodies from both sides of the border (PPs). Final beneficiaries of the funding would be the selected Hungarian and Croatian SMEs as Light Beneficiaries.

The current material serves as basis for implementation of the B Light Scheme, that is to be followed by a detailed Application Pack and Implementation Pack.

Contents

Contract context	2
Contents	3
1. Introduction	5
1.1. Programme background.....	5
1.1.1. SME development scheme in the Cooperation Programme.....	5
1.1.2. Expected results and outputs of the Scheme	6
1.2. Legal background	6
1.2.1. What is B Light Scheme?	6
1.2.2. Why B Light? – The purpose of applying the B Light Scheme	7
1.3. Purpose and structure of the Implementation Manual.....	8
2. Implementation structure	9
2.1. Programme level bodies	9
2.2. Role of the Beneficiaries	10
2.3. External Project Support Facility	11
2.4. First level control	11
2.5. The Light Beneficiaries (“B Lights”).....	12
3. Eligibility of Light Beneficiary applicants	14
3.1. Legal status.....	14
3.2. Geographical location	14
3.3. Professional and financial background	15
3.4. Exclusion criteria	15
4. State aid rules	17
4.1. Relevance of state aid rules in case of the different project partners	17
4.2. Application of de minimis rules.....	17
5. Eligibility of activities	20
5.1. Eligible activities of the LB and the Beneficiaries	20
5.2. Eligible activities of Light Beneficiaries	20
5.2.1. Partnership requirements	20
5.2.2. Eligible levels of cooperation	21
5.2.3. Eligible activities	22
6. Eligibility of costs	24
6.1. Eligibility of costs incurred at the LB and the Beneficiaries by cost categories	24

6.2.	Eligibility of costs incurred at the Light Beneficiaries by cost categories	25
7.	Project selection and evaluation system of Light Projects	28
7.1.	Role of the two-step selection system.....	28
7.2.	Selection Board.....	29
7.3.	1st selection step: Light Concepts (Concept notes)	29
7.4.	2nd selection step: Light Projects	30
7.5.	Contracting.....	32
8.	Implementation and monitoring.....	33
8.1.	Project duration.....	33
8.2.	Reporting procedures.....	33
8.3.	Payment of co-financing.....	34
8.4.	Role of External Project Support Facility (EPSF) in management of Light Projects.....	35
8.5.	Procurement rules.....	35
8.6.	Obligations of the Project Partners	36
	Glossary	37
	ANNEX I	38

1. Introduction

1.1. Programme background

1.1.1. SME development scheme in the Cooperation Programme

Recognising the need for economic development, one pillar of the strategy for the 2014-2020 cross-border cooperation programme between Hungary and Croatia became fostering value added business cooperation between SMEs operating on different sides of the border.

Priority axis 1 of the Interreg V-A Hungary-Croatia Co-operation Programme 2014-2020 aims to enhance the competitiveness of small and medium-sized enterprises (SMEs) in the border region.

Analysis has clearly shown that Hungarian and Croatian SMEs have not been able to recover from the shock of the economic crisis. Several analyses revealed that enterprises of the programme area have financial, innovation and networking problems. Weak internationalisation is one of the most crucial hindering factor which is especially true for the SMEs of the programme area with no improvement in the past years. Cross-border business cooperation in the programme area has multiple obstacles: language barrier, traditionally isolating borders hampered by the wartime period of the formerly Yugoslav countries, depressed socio-economic situation of the area, low inclination of SMEs for building international connections, serious problems with entrepreneurial skills and financing.

These cumulative problems could be addressed by a special local SME development scheme fostering development of local SMEs with strong focus on value added improvement via improving their financial background and simultaneously enhancing their cross-border business cooperation with high attention to provision of an all-round set of assistance to cooperating SMEs with built-in SME project generation and management services.

Investment priority focuses on fostering value added producing capability of enterprises operating in industry and services by boosting their product and service development activities through joint economic development actions which could generate higher gross value added (GVA) and consequently makes it possible to find new markets. By assistance of special development scheme SMEs are expected to develop joint projects aiming at establishing the following types of business cooperation: joint product, technology and service development, supplier chains, common marketing, future establishment of a joint venture. By enhancing business cooperation focusing on joint product and service developments, value added production of cooperating SMEs is expected to be improved in the bordering area. In general, it will help SMEs to become more stable and profitable in the border region that is expected to have a positive impact on employment, too. New business services to be made available for tourists visiting the natural and cultural attractions of the border area will contribute to increased attractiveness of the region and to increased revenues from and employment linked to tourism.

Crucial element of this special SME development scheme is built-in project generation and management support for cooperating SMEs based on the existing SME support networks with involvement of development agencies and enterprise development foundations operating in the programme area. This new SME development scheme enlarges the scope of their SME support activities in a complementary way (e.g. the new scheme amplifies the impact of existing micro-credit scheme of Hungarian enterprise development foundations). This special cooperation-driven SME development scheme could also serve as complementary set of actions to the SME development instruments of national mainstream programmes. Main complementarity of this scheme lies in the

strong focus on SME project generation and management assistance with a built-in mentoring mechanism supporting SMEs in their project activities through the whole duration of project implementation.

1.1.2. Expected results and outputs of the Scheme

Indicator	Measurement unit	Baseline	Target 2018	Target 2023
Average GVA per capita of industry and services sectors of the programme area	EUR	5,208.00	-	5,500.00
Number of enterprises receiving support	Enterprises	0	-	80
Number of enterprises receiving grants	Enterprises	0	15	80
Number of enterprises receiving non-financial support	Enterprises	0	-	80
Scheme spending (financial indicator)	EUR	0	2,200,000.00	11,718,000.00

1.2. Legal background

1.2.1. What is B Light Scheme?

The B Light Scheme is an SME development funding scheme specially designed for European Territorial Cooperation (ETC) cross-border cooperation (CBC) programmes.

Technically, it acts as one single CBC project implemented by a consortium of project partners that changes (grows) throughout the project period. The project is initiated and launched by the Project Partners (PPs): the Lead Beneficiary (LB) and the Beneficiaries (Bs), which are enterprise development agencies from the two sides of the border. The PPs submit the B Light Scheme project proposal and, after the project was approved by the Monitoring Committee, LB signs a Subsidy Contract with the Managing Authority and the LB and the Bs parallelly sign a Partnership Agreement as an Annex to the Subsidy Contract. After that, following a selection procedure, SMEs enter the project as Light Beneficiaries (B Lights) by signing the Partnership Agreement with the LB. As more and more SMEs enter the Scheme, the partnership grows bigger and bigger.

In the project, PPs manage the Scheme and provide different business support and consultancy services to SMEs. Light Beneficiaries implement joint investment projects to establish new business cooperation.

The original application of the Project Partners already covers the full budget of the B Light Scheme, covering both the financing of the business support activities of the LB and PPs and the financing of the future activities to be implemented by the Light Beneficiaries. This practically means that financial allocation for Light Beneficiaries is included in the B Light Scheme project Application Form as if Light Beneficiaries would be one single project partner. Later, as SMEs enter the partnership, this latter part of the budget is gradually allocated to them as Light Beneficiaries.

1.2.2. Why B Light? – The purpose of applying the B Light Scheme

In order to implement this strategy, the CBC programme required the design of an SME development scheme that works as a financial incentive to foster B2B cooperation, offering direct support to enterprises. In the same time, this new scheme must be built on the existing strengths of cross-border cooperation – especially the cooperation structure.

It must be recognised that such a scheme is highly innovative in the cross-border cooperation context. Although mainstream national or regional programmes in the Central and Eastern European area often involve support schemes targeted to SMEs, it is the contrary in the case of CBC programmes. Therefore, it is not surprising that right from the beginning, several fears and risks arose concerning the feasibility of an SME support scheme. The most important concerns were as follows:

SMEs have difficulties to find cross-border partners

- Even according to the findings of earlier analysis, the most important burden of cross-border cooperation for SMEs in the Hungary-Croatia border area is the identification of potential partners and markets. This is also true for the partner finding for a CBC project: how will SMEs be able to identify a partner from the other side of the border to submit a joint application for programme funding?

Taking the responsibility of a Lead Beneficiary

- The Lead Beneficiary principle is applied throughout the ETC programmes. In a specific project involving several SMEs into a consortium, it would mean that one of the enterprises shall take a certain responsibility for the project as a whole, and the partnership as a whole – including the activities of the other companies taking part of the project. This is a risk that only very few SMEs are ready to take.

Complicated administration

- The application and project selection procedure, the contracting, reporting, monitoring and financing processes of a CBC project requires heavy administration, which, in most cases, is a serious burden for SMEs.

Financial aid is not attractive enough compared to national mainstream programmes

- Several mainstream programmes offer grants to SMEs, reaching 50-70% of grant intensity.

Projects with no additional B2B cooperation

- Additionality is a crucial factor for EU financing. Any support scheme must be able to guarantee that it finances the establishment of additional business cooperation, and not a maintenance or reformulation of the existing.

The goal was to design a support scheme which offers a solution of all the above concerns. Three different options with different legal and structural background were analysed:

1. direct development of joint SME development projects (SMEs act as beneficiaries)
2. application of global grant scheme
3. application of B Light Scheme

Following a comparative analysis of the three alternatives, the B Light Scheme was selected as the most appropriate tool to support SMEs in this cross-border cooperation context.

The B Light Scheme answers all above concerns, while offering a great flexibility during implementation:

- PPs offering project development services, administrative backstopping and taking the LB responsibility according to the Lead Beneficiary principle.
- In the B Light Scheme project part of the budget is allocated to specific activities for which the ultimate beneficiaries of the grants (SMEs – Light Beneficiaries) are not yet known (but they will be appointed through open Call for Proposals).
- SMEs can join the project at a later stage as Light Beneficiaries so the flexibility of this scheme is high at the moment of the B Light Scheme project approval.
- The Light Beneficiaries (SMEs) can join the project as final beneficiaries (receiving grants) at a later stage during the project implementation, without the need to change the project budget or the project Subsidy Contract.
- The B Light Scheme can offer a high grant intensity using the 'de minimis' rule.
- The Scheme provides clear criteria on the level of eligibility and indicators, assuring the additionality of supported business cooperation.

A huge advantage of B Light Scheme compared to global grant scheme is that B Light project acts as a normal CBC project, so this scheme does not fall under the rules of Article 123(7) of CPR. This is because the 'Lead Partner principle' rule is applied in CBC projects. Subsidy contract is only signed by the Managing Authority (MA) and the Lead Beneficiary. All other project partners are involved into the project through Partnership Agreements. All responsibilities of project implementation towards the MA should be borne by the Lead Beneficiary.

1.3. Purpose and structure of the Implementation Manual

The purpose of this Manual is to provide an overall description of the operation of the B Light Scheme to be implemented under Priority 1 of the Interreg V-A Hungary-Croatia Cooperation Programme 2014-2020. As such, the Manual shall serve as a basis for all implementation activities by all concerned stakeholders: the programme authorities and the project partners of the Scheme shall design and implement all their activities according to the structures and processes as stipulated in this Manual.

However, the Implementation Manual is not designed to provide the totality of the information necessary for the implementation of the Scheme. Actually, it is presumed and required that the users of this Manual have a thorough knowledge of the CBC context in which the B Light Scheme is implemented, and especially, on the content of the Cooperation Programme itself, all relevant community and national legislation (including, among others, the rules of ERDF and ETC implementation, state aid rules, public procurement legislation etc.) and programme implementation documents.

2. Implementation structure

2.1. Programme level bodies

In respect of the B Light Scheme, the following bodies have responsibilities in the implementation:

- Monitoring Committee

The Monitoring Committee (MC) is the main decision-making body of the Interreg V-A Hungary-Croatia Cooperation Programme, composed of the representatives of the programme area counties and the responsible state bodies. The MC is responsible to approve the Scheme (the Application Form and the Implementation Manual), as a special project and monitors its implementation, making decision on changes on level of the Scheme, in line with the Subsidy Contract.

The MC shall have the following specific tasks related to the Scheme:

- decision on content of the Calls for Light Concepts and Calls for Light Project Proposals, including the evaluation system;
- half-year supervision of B Light Scheme implementation and proceedings, especially in terms of meeting the indicators and absorption of funds available;
- approval of changes on level of the Scheme;
- approval of annual reports on progress of the B Light Scheme.

Working body of the MC is the Joint Secretariat (JS). The JS shall be supported by the Lead Beneficiary (HAMAG BICRO), providing all necessary information on the proceedings of the B Light Scheme.

- The Managing Authority

The Managing Authority (MA) bears overall responsibility for the implementation of the Cooperation Programme, including the Scheme. The MA is the Hungarian Prime Minister's Office, based in Budapest, Hungary. The MA acts as signatory of the Subsidy Contract of the Scheme, having responsibility and competences in monitoring it in line with the Subsidy Contract.

- Certifying Authority

The Certifying Authority (CA) is responsible for certifying declarations of expenditure and applications for payment, including the Scheme as well.

- Audit Authority

The Audit Authority (AA) is independent from the MA and the CA, responsible for verifying the effective functioning of the management and control system, including control of the Scheme and the Light Projects as well.

- Joint Secretariat

The Joint Secretariat (JS) is the administrative body supporting the MA, the MC and the SC. The JS is set up at the Széchenyi Programme Office Nonprofit Llc., headquartered in Budapest, but having contact points in Čakovec, Osijek and Pécs. As the Scheme is a project in itself, the JS is responsible for administrative monitoring

of it. Scheme level progress reports, final report and application for reimbursements after each project period (trimester) shall be sent to the JS, followed by a procedure of approval regulated by the Subsidy Contract. The JS has also responsibilities in endorsing changes on level of the Scheme, stipulated by the Subsidy Contract.

As tasks in connection with management of the application procedure of the Light Projects are carried out by the Scheme's partnership, the JS has no role in evaluation of Light Project Proposals, however supervises selection procedure delegating non-voting member to the Selection Board.

2.2. Role of the Beneficiaries

The Scheme in terms of partnership matches general cross-border projects: having a Lead Beneficiary, several Beneficiaries and the SMEs as Light Beneficiaries. The latter are to be selected through two-step Call for Proposals (CfPs).

- Lead Beneficiary: HAMAG BICRO

The Lead Beneficiary (LB) bears responsibility for overall coordination of the implementation of the Scheme, in line with the Subsidy Contract signed with the MA.

The LB is responsible for the sound and prudent management of the CfPs in both steps. In the 1st step evaluation of the Light Concepts and decision making of the Selection Board is coordinated by the LB. The LB is responsible to keep contact with the Light Beneficiaries, inform them on selection of their Light Concepts. Evaluation of the 2nd step Light Project Proposals is also coordinated by the LB, with involvement of the Beneficiaries' internal staff and hired external experts for SME project assessment. The LB is responsible for coordination of decision making of the Selection Board on the Light Project Proposals and contacts the Light Beneficiaries on the decision. Light Beneficiaries of the selected Light Projects shall sign Partnership Agreement with the LB.

The LB operates the online B Light Platform as the official web portal of the Scheme. The Light Projects can be submitted online through this B Light Platform.

The LB is obliged to sound administrative and financial management of the Scheme, including submission of its own beneficiary level progress report and final report to the responsible First Level Control (FLC) body in Croatia, just like submitting the Scheme level progress and final report, accompanied with the application for reimbursement to the JS.

- Beneficiaries: county level SME development agencies

The Beneficiaries are responsible for coordinating the project activities in their respective counties. Seven Beneficiaries are involved: 1-1 from each of the bordering counties of Hungary and Croatia. As in Croatia only the directly bordering counties' (Koprivnica-Križevci, Međimurje, Osijek-Baranja, Virovitica-Podravina) SME development agencies are involved as Beneficiaries, responsibility of coordinating activities in the further eligible counties (Bjelovar-Bilogora, Požega-Slavonia, Vukovar-Srijem and Varaždin) are to be divided among the Beneficiaries.

The Beneficiaries' main task is to promote and raise awareness about the Scheme among the SMEs in the border area and play an active role in project generation: organising promotion events, B2B meetings and consultations in order to identify the potential Light Beneficiaries and Light Project initiatives.

The Beneficiaries participate in evaluation of both the Light Concepts (1st step) and Light Project Proposals (2nd step), however in the 2nd step staff of the LB and the Beneficiaries are supported by external SME development experts as assessors if necessary. Beneficiaries take part in the Selection Board and shall assist to the LB in preparing the proposal for decision making on the 1st step Light Concepts and 2nd step Light Project Proposals.

Avoidance of conflict of interest: staff involved in the evaluation phase from side of the Bs should be different from the persons involved in generation of the Light Concepts.

Beneficiaries are also responsible for the sound management of their project parts, including submission of their beneficiary level progress reports and final report to the territorially responsible FLC and support the LB in the preparation of the Scheme level progress reports, the final report and the application for reimbursement.

2.3. External Project Support Facility

As the Scheme – due to its bilateral cross-border character – is a unique initiative, preparation and implementation of the Light Projects require special approach and preparedness from the participating SMEs. In order to cope with these challenges and generate real added value in cross-border economic relations, Light Beneficiaries will receive free-of-charge technical assistance by the External Project Support Facility (EPSF).

EPSF has the following assignments:

- provision of project development assistance to SMEs as Light Beneficiaries whose Light Concept were appointed for further development in the 1st selection step in developing their Light Project Proposals between the 1st and 2nd selection step;
- provision of project management assistance to SMEs as Light Beneficiaries in coping with the administrative and financial management requirements and the language barrier during implementation of their Light Projects after the 2nd selection step (see Chapter 8.4.).

EPSF assistance is selected by the LB through an open public procurement tender with assignment of an expert consortium composed of external SME development experts both from Hungary and Croatia.

Members of EPSF consortium should have solid in-field experience in the border region and should possess references in preparation or implementation of SME development schemes and preparation and management of cross-border cooperation and SME development projects.

Operation of EPSF consortium will be contracted and financed by the LB.

2.4. First level control

Verification of expenditures and approval of partner level progress reports is done by the territorially competent First Level Control (FLC). The FLC is delegated to the following bodies:

- In Hungary: Széchenyi Programme Office Llc.: 7621 Pécs, Széchenyi tér 9.; 8900 Zalaegerszeg, Petőfi u. 24.
- In Croatia: Agency for Regional Development of the Republic of Croatia: 10000 Zagreb, Ulica grada Vukovara 284.

The LB and the Beneficiaries are responsible to submit their beneficiary level progress report after the end of each period (trimester) to these bodies that carry out the controlling (including document-based and on-the-spot checks) and verification procedure accordingly to the stipulations of the Subsidy Contract and the financial implementation rules.

Light Beneficiaries will be also responsible to compile their partner level progress reports and submit to the territorially competent FLC. Preparation of their partner level progress reports will be facilitated by the EPSF. After verification of the expenditures of the Beneficiaries and the Light Beneficiaries the FLC shall issue a Declaration on Verification of Expenditure (DoVE) that are to be delivered to the LB who shall prepare the project level progress report with the application for reimbursement and submit it to the JS.

2.5. The Light Beneficiaries (“B Lights”)

The Light Beneficiaries are the beneficiary SMEs selected through a two-step Call for Proposal in order to receive a subsidy from the Scheme. The applying Light Beneficiaries have to be registered or have to have a branch operating in the programme area of the Cooperation Programme. Once the Light Beneficiaries' Light Project has been selected, the Light Beneficiaries sign a Partnership Agreement with the LB. Light Beneficiaries are mainly responsible for the implementation of their Light Project part and they should cooperate with their Light Beneficiary(ies) from the neighbouring country so as to meet their Light Project level indicators set out in their Light Project documentation.

Light Beneficiaries are responsible for the sound administrative management of their Light Project parts, including submission of their partner level progress reports and final report to the territorially responsible FLC and provide in-depth information on the project part's activities to the project level progress reports and the final report. In these administrative obligations they will be assisted by the ESPF.

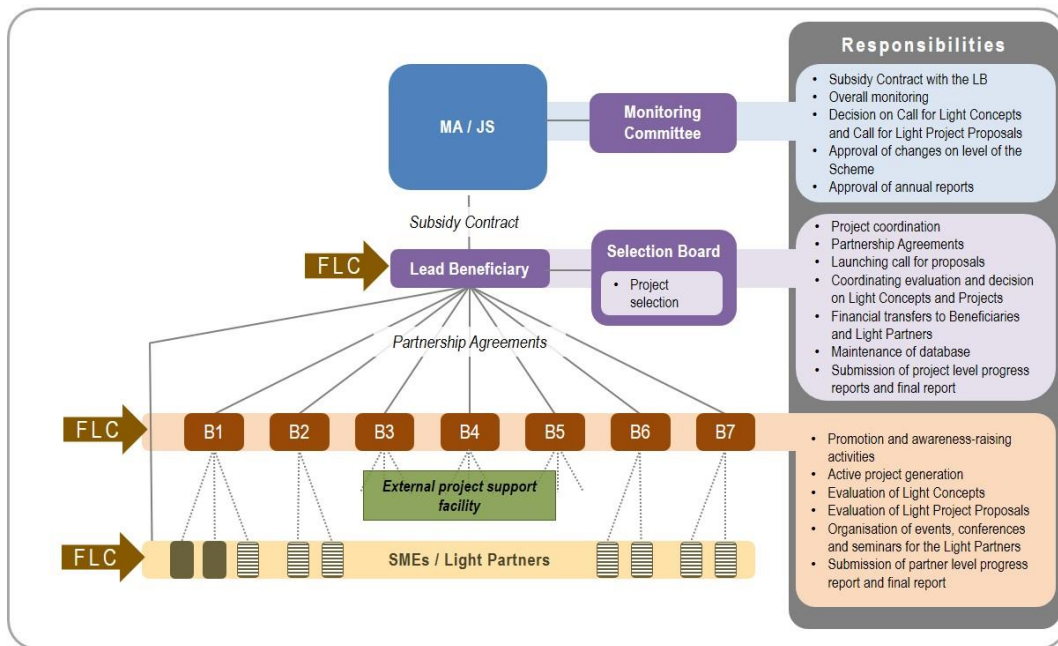

Figure 1: Implementation structure of B Light Scheme.

3. Eligibility of Light Beneficiary applicants

3.1. Legal status

Light Beneficiary should fall into the category of small and medium-sized enterprises (SMEs) stipulated in 651/2014/EU Regulation, Annex 1.

Owner interweaves should be excluded among Light Beneficiaries of each Light Project. This means that Light Beneficiaries cooperating under a single Light Project should be autonomous enterprises from each other, stipulated under 651/2014/EU Regulation, Annex 1., Article 3. Partner or linked enterprises cannot be granted under a single Light Project.

3.2. Geographical location

Each Light Beneficiary should have its seat or branch registered and acting in the eligible programme area (NUTS III level counties):

Hungarian side:

- Zala county (HU223);
- Somogy county (HU232);
- Baranya county (HU231).

Croatian side:

- Međimurska county (HR 046);
- Koprivničko-križevačka county (HR 045);
- Virovitičko-podravska county (HR 048);
- Osječko-baranjska county (HR 04B);
- Varaždinska county (HR 044);
- Bjelovarsko-bilogorska county (HR 047);
- Požeško-slavonska county (HR 049);
- Vukovarsko-srijemska county (HR 04C).



Figure 2: The eligible programme area.

Light Project activities have to be implemented in the eligible programme area listed above.

The Light Beneficiary should have its seat or branch existing in the eligible programme area for at least one year counted from the date of submission of the Light Concept.

3.3. Professional and financial background

Basic eligibility criteria for Light Beneficiaries are as follows:

- Light Beneficiary or its owner company having more than 50% of ownership rights over the Light Beneficiary or its linked enterprise through a natural person having at least one closed business year;
- Light Beneficiary or its owner company having more than 50% of ownership rights over the Light Beneficiary or its linked enterprise through a natural person employed at least one employee in its last closed business year;
- Light Beneficiary's equity is positive for the last closed business year.

Other than above written basic eligibility criteria may be stipulated at a later stage on call level, in order to promote innovative and fast-growing business cooperation, first of all in the IT sector.

Light Beneficiaries will be measured against a set of criteria related to their professional and financial background:

- Light Beneficiaries have to take direct responsibility for the preparation and management of their Light Project part both from professional and financial point of view and may not act as intermediaries.
- Light Beneficiaries must be experienced and able to demonstrate their capacity to manage their share of activities in the Light Project.
- Light Beneficiaries must prove their financial and administrative capacity to manage their share of the Light Project (ensuring pre-financing and own contribution).

3.4. Exclusion criteria

All potential Light Beneficiaries shall prove their professional and financial liability by not falling under any of the cases presented below. In order to ensure the fulfilment of the financial commitments, Light Beneficiaries cannot receive funding if one or more of the following cases apply to them:

- Enterprises active in the following sectors (gaining more than 50% of their annual turnover from these sectors in their past closed business year) are excluded:
 - NACE code¹ A - Agriculture, forestry and fishing (01 –03)
- Light Projects containing development of the following activities:
 - fishery and aquaculture,
 - primary production, processing and marketing of agricultural products listed in Annex I to the Treaty (see Annex I of Implementation Manual),
 - the establishment and operation of a distribution network towards third countries or Member States;
- Eligible activities of Light Project business cooperation do not belong to the NACE codes representing the target economic sectors of B Light Scheme (see Chapter 5.2.2.);
- Their business is in difficult situation (according to Regulation 800/2008/EK);

¹ See: NACE Rev. 2 Statistical classification of economic activities in the European Community, Eurostat, European Communities, 2008.

- They are bankrupt, being wound up, liquidated or having their affairs administered by the courts;
- They have entered into an agreement with creditors;
- They have suspended business activities;
- They are subject of proceedings concerning those matters, or are in any analogous situation arising from a similar procedure provided for in national legislation or regulations;
- They do not have valid registration to pursue their activities or they have been convicted of an offence concerning their professional conduct by a judgement which has the force of 'res iudicata', further they have been guilty of grave professional misconduct proven by any means which the MA/NA can justify;
- They have not fulfilled their obligations relating to the payment of social security contributions or the payment of taxes in accordance with the national legal provisions;
- They have been the subject of a judgement which has the force of 'res iudicata' for fraud, for corruption, for severe breach of contract in connection to obligations stemming from public procurement rules or from rules governing the use of Community funding or national subsidies, for involvement in a criminal organisation or for any other illegal activity detrimental to the Community's financial interests;
- They are subject to a conflict of interests connected to their participation in the present B Light Scheme;
- They are guilty of misrepresentation in supplying the information required by the LB/MA/NA as a condition of participation in the Scheme or in failing to supply information;
- They have attempted to obtain confidential information or to influence the Selection Board during the evaluation process of their Light Concept or Light Project Proposal.

Light Beneficiaries are obliged to sign declarations that refer to the non-existence of the above listed circumstances.

4. State aid rules

As the implementation of the B Light Scheme offers state support to undertakings, the Community competition rules for state aid must be fully respected. All aids to undertakings under this scheme will be granted as de minimis aid.

4.1. Relevance of state aid rules in case of the different project partners

The funding received by the Project Partners (Lead Beneficiary and the 7 Beneficiaries) to cover the costs related to their tasks to manage the B Light Scheme is not state aid.

Technical assistance of External Project Support Facility (EPSF) provided to Light Beneficiaries is state aid (de minimis grant), whereas the beneficiaries of the aid are the Light Beneficiaries that receive in kind free-of-charge services. This technical assistance state aid is received by Light Beneficiaries as lump sum for the following activities (exact amount specified in the Call for Light Project Proposals):

- project development assistance of EPSF to each Light Beneficiary between the 1st and 2nd selection step;
- project management assistance of EPSF to each Light Beneficiary after the 2nd selection step.

The funding received by granted Light Beneficiaries for implementation of their eligible activities within the Light Project is also state aid (de minimis grant), whereas the beneficiaries of the aid are the SMEs receiving the grant.

Therefore, the state aid rules shall apply in case of the Light Beneficiaries, and for each of them, the totality of the aid received in the forms of in kind free-of-charge services and direct financial support shall be considered.

According to the above-mentioned state aids received by Light Beneficiaries, the following declarations for state aid should be issued and sent to the JS by each of the Light Beneficiaries:

- de minimis self-declaration for receiving project development assistance of EPSF;
- de minimis self-declaration for receiving project management assistance of EPSF;
- de minimis self-declaration for receiving funds from B Light Scheme for implementation of their eligible activities.

4.2. Application of de minimis rules

EU and state contribution (both in kind and financial) provided by the B Light Scheme to Light Beneficiaries will be granted solely under the de minimis rule, according to Commission Regulation (EU) No 1407/2013 of 18 December 2013 on the application of Articles 107 and 108 of the TFEU to de minimis aid (Regulation). Titles under the General Block Exemption Regulation (GBER) will not be applied.

However detailed rules on de minimis aid to be found in the regulation, the main consequences important to highlight in the selection phase of Light Projects are as follows.

The total de minimis aid granted to each Light Beneficiary shall not exceed EUR 200,000 per Member State over the present and the previous two fiscal years. This threshold for each Light Beneficiary exists separately for the

two Member States, meaning that the same Light Beneficiary can be granted a de minimis aid of maximum EUR 200,000 in Croatia plus a de minimis aid of maximum EUR 200,000 in Hungary (i.e. the de minimis aid received in different Member States are not to be cumulated).

The linked enterprises with overlapping ownership structure are considered as one single enterprise, therefore the de minimis aid received by these Light Beneficiaries must be cumulated and the EUR 200,000 threshold must be respected for the cumulated amount. For details, please consult Article 2.2 of the Regulation.

As part of the selection process for Light Projects each Light Beneficiary shall declare the total amount of de minimis aid granted to the Light Beneficiary and its linked enterprises in the present and the previous two fiscal years in Hungary and Croatia. This amount will be deducted from the EUR 200,000 threshold to define the maximum aid grantable to the Light Beneficiary.

When defining the granting Member State for the de minimis aid under the B Light Scheme, the proportional approach will be applied. This means that the aid granted to each Light Beneficiary (including both direct financial support and in kind free-of-charge services of EPSF) will be divided 50-50% between aid granted by Croatia and aid granted by Hungary. From the perspective of the Light Beneficiary, it means that half of the received grant shall be deducted from its Hungarian de minimis threshold, and the other half shall be deducted from its Croatian de minimis threshold. This also means that under B Light Scheme no Light Beneficiary may receive grant (including both financial and in kind) higher than the double value of the lower sum of the remaining amounts of its de minimis thresholds in the two countries (see Figure 3).

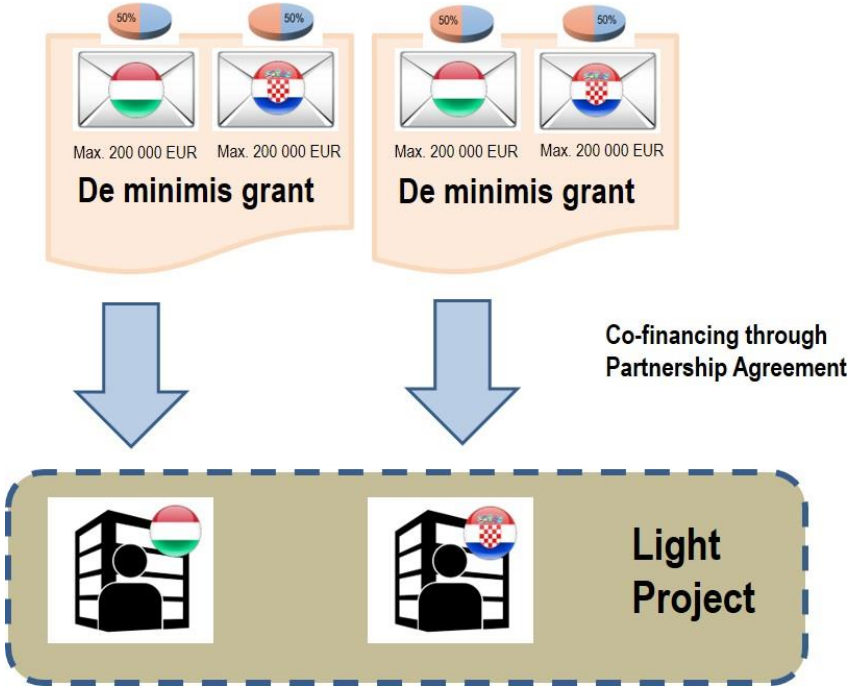

Figure 3: Application of the de minimis rule for financing of Light Projects.

The aid grantor shall inform the Light Beneficiary about the prospective amount of the aid (expressed as gross grant equivalent) and of its de minimis character, and the Member State granting the aid, making express reference to Commission Regulation (EU) No 1407/2013 and citing its title and publication reference in the Official Journal of the EU.

Records regarding de minimis aid shall be maintained for 10 years from the date on which it was granted, and such invitation of the grantor the Light Beneficiary is obliged to present all the documents. On request of the EC information shall be provided on de minimis aid within 20 workdays.

As B Light Scheme provides de minimis grant to SMEs, Light Projects containing development of the following activities are excluded:

- fishery and aquaculture,
- primary production, processing and marketing of agricultural products listed in Annex I to the Treaty (see Annex I of Implementation Manual),
- the establishment and operation of a distribution network towards third countries or Member States.

5. Eligibility of activities

5.1. Eligible activities of the LB and the Beneficiaries

Eligible activities in case of the LB and the Beneficiaries are identical with the eligible activities laid down for other soft-type projects of the Cooperation Programme.

Compulsory eligible activities of the LB and the Beneficiaries are as follows:

- Project administration and management: management of contractual relationships with the MA and the Beneficiaries; organisation of internal partner meetings; compiling progress and financial reports on level of the Beneficiaries and the Scheme; monitoring of budget spending and the achievement of indicators, purchase of equipment for general office use.
- Information and publicity: providing information about the Scheme and its results to the general public in various media and events (inside and outside the programme area).
- Organisation of promotional and B2B events for potential Light Beneficiaries.
- Organising conferences and seminars for the exchange of experiences about Light Projects.
- Development and maintenance of database and information system about the activities and funding of the Light Projects.
- Establishment and running of the online B Light Platform for submission of Light Concepts and Light Project Proposals, event calendar and partner search facility for potential Light Beneficiaries.

In line with the role of the LB and the Beneficiaries (see Chapter 2.2.) the following optional eligible activities may be implemented:

- Hiring and supervising the work of expert consortium assisting the Light Beneficiaries in Light Project development and management (EPSF).
- Organisation of educational seminars for Light Beneficiaries on development and implementation of their projects.
- Organisation of events focusing on exchange of experience with similar SME development schemes of other Interreg programmes Europe-wide.

Works activities and purchase of equipment beyond general office use are not eligible.

5.2. Eligible activities of Light Beneficiaries

5.2.1. Partnership requirements

Light Projects should consist of at least two cooperating Light Beneficiaries; maximum number of Light Beneficiaries in a Light Project is 4.

Each Light Project should consist of at least one Light Beneficiary from each side of the border:

- at least one Light Beneficiary should have its seat or its branch and should operate in the Hungarian programme area (in one of the following counties: Baranya, Somogy, Zala),

- at least one Light Beneficiary should have its seat or its branch and should operate in Croatian programme area (in one of the following counties: Bjelovar-Bilogora, Koprivnica-Križevci, Međimurje, Osijek-Baranja, Požega-Slavonia, Varaždin, Virovitica-Podravina, Vukovar-Srijem).

Each Light Project's Light Beneficiaries should sign Partnership Agreement with the Lead Beneficiary after the Light Project was granted by the Selection Board. Each Light Beneficiary is mainly responsible for the implementation of its own Light Project part.

However, each Light Beneficiary is also responsible for meeting their commonly set Light Project level indicators. In order to clarify the exact Light Project level responsibilities of each Light Beneficiary, the Light Project includes the commonly defined Light Project level indicators and the breakdown of indicators by Light Beneficiaries.

Like regular cross-border cooperation project partnerships, partnership of each Light Project should be balanced with a rational and efficient division of tasks and responsibilities among Light Beneficiaries. A Light Project partnership shall be composed of Light Beneficiaries that may be linked professionally to the Light Project and that may have significant contribution and impact within the partnership. In order for a partnership to be operable and effective it must aggregate partners with common needs and objectives, while specific knowledge and expertise have to be ensured throughout.

The Scheme is generally not in favour of funding of one-sided Light Projects, however, based on experience of the first call, at a later stage one-sided projects may be allowed up to the decision of the MC, if this solution may bring more quality projects.

5.2.2. Eligible levels of cooperation

Minimum cooperation level requirement within a Light Project is a value-added cross-border joint technology, service and product development by the cooperating Light Beneficiaries operating on different sides of the border for setting up cross-border supplier networks and/or for jointly engaging into new market.

Reflecting on the minimum required cooperation level, two result indicators should be met by each Light Project proving their value-added cooperation:

- Documentary evidence of signed contractual business agreement with third parties for selling the commonly developed new or upgraded product, technology or services by either or all of Light Beneficiaries within the sustainability period of their Light Project (2 years after completion of their Light Project).
- Reaching the minimum value of selling of commonly developed new or upgraded product, technology or services by either or all of Light Beneficiaries within the sustainability period of their Light Project (2 years after completion of their Light Project), proven by trial balance of the Light Beneficiaries – minimum value is to be specified in the Application Pack.

Reaching the following additional eligible levels of cooperation means more valuable Light Project:

- Previous record of development activities and cross-border business cooperation of the Light Beneficiaries;
- Human capacities of Light Beneficiaries and their competences in relation to Light Project content;

- Innovative character of product, technology or services development;
- Business potential of product, technology or services development;
- Methodology of project implementation;
- Relevance and preparedness of Light Project budget.

5.2.3. Eligible activities

Eligible activities of Light Project business cooperation should belong to the following NACE codes² representing the target economic sectors of B Light Scheme:

C – Manufacturing (10 - 33)

D – Electricity, gas, steam and air conditioning supply (35)

E – Water supply; sewerage; waste management and remediation activities (36 - 39)

F – Construction (41 - 43)

G – Wholesale and retail trade, repair of motor vehicles and motorcycles - only one of the Light Beneficiaries can be granted to implement these types of activities within a single Light Project (45 - 47)

H – Transportation and storage (49 - 53)

I – Accommodation and food service activities – excluding extension and quality improvement of accommodation capacities, focusing on quality service development to be stipulated on call level (55 - 56)

J – Information and communication (58 - 63)

M – Professional, scientific and technical activities (69 - 75)

N - Administrative and support service activities, only the following activities:

- Employment activities (78)
- Travel agency, tour operator reservation service and related activities (79)
- Security and investigation activities (80)

P – Education (85)

Q – Human health and social work activities (86 - 88)

R - Arts, entertainment and recreation, only the following activities:

- Creative, arts and entertainment activities (90)
- Libraries, archives, museums and other cultural activities (91)
- Sports activities and amusement and recreation activities (93)

² See: NACE Rev. 2 Statistical classification of economic activities in the European Community, Eurostat, European Communities, 2008.

All eligible activities of each Light Beneficiary should belong to any of the above listed NACE codes. Activities outside these NACE codes are ineligible. Application Pack may stipulate specific maximum thresholds of grant allocation for specific sectors.

Independently eligible activities:

- Development of new technology, service or product.
- Purchase of equipment for the sake of joint technology, service and product development.
- Purchase of equipment for the sake of moving materials, packaging and storing in the phase of joint technology, service and product development (purchase of vehicles is prohibited).
- ICT development: purchase and installation of new hardware and software equipment (with the exception of purchase of equipment for general office use).
- Activities for entering new markets of jointly developed technology, service and product:
 - Appearance on events, fairs, business meetings, international project development workshops organised inside or outside the programme area;
 - Organisation of business seminars, workshops, conferences;
 - International market surveys;
 - Development or upgrading of marketing tools and materials in foreign language (design, layout, elaboration);
 - Marketing actions targeting markets inside or outside the programme area.
- External expertise for the sake of developing joint technology, service and product.

Eligible activities to be combined with independently eligible activities:

- Investment in basic infrastructure development and construction, enlarging, restructuring, refurbishment or modernisation of building for the sake of operating equipment for joint technology, service and product development.
- Purchase of equipment for general office use.
- Purchase of intangible fixed assets: purchase of patent and other kind of intangible assets (licence, protection), purchase of utilisation rights for intangible assets.
- Organisation of trainings, seminars for improving knowledge on developing joint technology, service and product.
- Employment of new and existing employees for the sake of developing joint technology, service and product.
- Light Project administration and management: organisation of Light Beneficiary meetings; collection of documents of expenditure, maintenance of files, public procurement activities on level of the Light Beneficiaries (Light Project management activities beyond the responsibilities of EPSF, see Chapter 8.4.).

Purchase of second hand equipment is not eligible in general, but Application Pack may stipulate special conditions by which purchase of second hand equipment could be eligible.

In case of Light Projects with works project elements, the Light Project Proposals should possess constructions plans ready to be submitted to the relevant authority in order to acquire the building permit, if the activity is subject to building permit.

6. Eligibility of costs

This chapter sets out the key rules on the eligibility of costs under the B Light Scheme. Further details concerning Light Projects – including the specific sums for simplified cost options (SCOs) – are specified in the Application Pack.

6.1. Eligibility of costs incurred at the LB and the Beneficiaries by cost categories

Preparation costs

Preparation costs represent a special eligible expenditure that is automatically granted to the B Light Scheme project that successfully signs the Subsidy Contract for the EU contribution with the MA. The total amount of preparation costs that can be given to the project is EUR 15,000 as a lump sum. The Project Partners have to decide in advance about the distribution of the lump sum of preparation costs among themselves (not including Light Beneficiaries).

Any difference between the granted lump sum and the costs occurred in reality for preparation activities is neither checked nor further monitored by the Cooperation Programme implementing structure. Project Partners do not need to document that the expenditure has been incurred and paid or that the expenditure corresponds to reality.

Staff costs

Staff costs are eligible for both existing and new, additional employees, employed for the purposes of the implementation of the B Light Scheme project.

As regard to the eligibility of staff costs incurring at LB and Bs, the same implications apply as for all other projects under the Cooperation Programme (see Guidelines for Applicants, pages 68-75), with the exception that solely the calculation method based on real costs can be applied for all staff costs related to the activities of the LB and Bs (see Chapter 5.1.). Flat rate financing is not applicable.

Office and administrative expenditure

As regard to the eligibility of office and administrative expenditure incurring at the LB and Bs, the same implications apply as for all other projects under the Cooperation Programme (see Guidelines for Applicants, pages 75-76). This means that the budget line is to be calculated as a flat rate of 15% of the real staff costs.

Any difference between the granted flat rate based sums and the costs occurred in reality for these activities is neither checked nor further monitored by the Cooperation Programme implementing structure. Beneficiaries do not need to document that the office and administration expenditure has been incurred and paid or that the flat rate corresponds to the reality.

Travel and accommodation expenses

Travel and accommodation expenses (e.g. for participation in project meetings, project site visits, meetings with the programme bodies, seminars, conferences etc.) of the staff – being employed by the LB or the Bs (not including Light Beneficiaries) – involved in the implementation of the B Light Scheme are eligible costs if they are incurred for performing tasks directly related to the project activities. As regards these expenses, the same

implications apply as for all other projects under the Cooperation Programme (see Guidelines for Applicants, pages 77-80).

External expertise and services

As regard to the eligibility of expenditure related to external expertise and services incurring at LB and Bs, the same implications apply as for all other projects under the Cooperation Programme (see Guidelines for Applicants, pages 80-85), with the following exemption:

- External expertise and services costs related to investment/works activities, such as technical planning, supervisor of engineering, architect's site supervision, are not eligible, as no respective investment/works activities are foreseen for these beneficiaries.

Purchase of equipments

In case of the LB and Bs, only the expenditure related to the equipment for general (office) use, such as computers, office furniture etc. is eligible, which is used for the daily work of the project staff and which is not already included under the 'Office and administrative' expenditure budget line.

Purchase of equipment for general (office) use (called office equipment, meaning purchase of computers, office furniture etc.) is an eligible expenditure that is automatically granted to the selected project in the form of a lump-sum for the maximum of 1,000 EUR per Project Partner.

Any difference between the granted lump sum and the costs occurred in reality for office equipment is neither checked nor further monitored by the Cooperation Programme implementing structure. Beneficiaries do not need to document that the expenditure has been incurred and paid or that the expenditure corresponds to reality.

Investment/Works

Expenditure related to investments or works activities are not eligible for the LB and Bs.

Ineligible expenditure

As regard to ineligible expenditures, the same implications apply as for all other projects under the Cooperation Programme (see Guidelines for Applicants, pages 91-93).

Revenues generated by the projects

As regard to the revenues generated by the project incurring at LB and Bs, the same implications apply as for all other projects under the Cooperation Programme (see Guidelines for Applicants, pages 93-95).

6.2. Eligibility of costs incurred at the Light Beneficiaries by cost categories

Preparation costs

Preparation costs represent a special eligible expenditure that is automatically granted to the Light Beneficiaries who successfully sign Partnership Agreement with the LB for implementation of their Light Project for the costs related to the preparation of the Light Concepts - lump sum amount to be specified in the Application Pack.

Any difference between the granted lump sums and the costs occurred in reality for these activities is neither checked nor further monitored by the Cooperation Programme implementing structure. Light Beneficiaries do not need to document that the expenditure has been incurred and paid or that the expenditure corresponds to reality.

Staff costs

Staff costs for Light Beneficiaries are eligible for both existing and newly hired employees, employed for the purposes of the implementation of the Light Project. Light Beneficiaries may choose in their Light Project Proposal to apply either standard scales of unit costs or calculation on real cost basis. This choice shall remain unchanged during implementation of the Light Project part.

In case of standard scales of unit costs, the Application Pack defines monthly unit costs for different staff categories upon qualification requirements.

If an employee is not employed full time for the Light Project, the unit cost shall be applied proportionally according to the full-time equivalent (FTE) rate.

Light Beneficiaries as beneficiaries are required to document and report the fact of employment, the position and the qualification of the employee according to the relevant staff category, the FTE of the employment and the employment period. The eligible cost is then calculated as a multiplication of the relevant monthly staff unit cost, the FTE ratio and the number of months of employment.

In case of applying standard scales of unit costs, any difference between the granted unit cost based amount and the costs occurred in reality for staff costs is neither checked nor further monitored by the Cooperation Programme implementing structure. Light Beneficiaries do not need to document that the expenditure has been incurred and paid or that the expenditure corresponds to reality.

Staff costs in total are not allowed to amount more than 80% of the respective Light Beneficiary's budget.

Office and administrative expenditure

Office and administrative expenditures incurring at Light Beneficiaries are eligible costs if they are incurred for performing tasks directly related to the project activities. Detailed eligibility rules of expenditure are to be specified in the Application Pack. This budget line is to be calculated as a flat rate of 15% of the staff costs.

Any difference between the granted flat rate based sums and the costs occurred in reality for these activities is neither checked nor further monitored by the Cooperation Programme implementing structure. Light Beneficiaries do not need to document that the office and administration expenditure has been incurred and paid or that the flat rate corresponds to the reality.

Travel and accommodation expenses

Travel and accommodation expenses of the staff – being employed by the Light Beneficiaries – involved in the implementation of the Light Projects are eligible costs if they are incurred for performing tasks directly related to the project activities. Detailed eligibility rules of expenditure are to be specified in the Application Pack.

External expertise and services

Expenditures related to external expertise and services incurring at Light Beneficiaries are eligible costs if they are incurred directly for development activities of the Light Projects. Detailed eligibility rules of expenditure are to be specified in the Application Pack.

Purchase of equipment

Purchase of equipment incurring at the Light Beneficiaries are eligible costs if they are regarded as content-related, thematic equipment relevant for the implementation of the Light Projects. Detailed eligibility rules of expenditure are to be specified in the Application Pack.

Purchase of equipment for general (office) use (called office equipment, meaning purchase of computers, office furniture etc.) is also an eligible expenditure that is automatically granted to the selected Light Projects in the form of a lump sum - lump sum amount to be specified in the Application Pack.

Any difference between the granted lump sums and the costs occurred in reality for these activities is neither checked nor further monitored by the Cooperation Programme implementing structure. Light Beneficiaries do not need to document that the expenditure has been incurred and paid or that the expenditure corresponds to reality.

Investment/Works

Investment and works expenditures incurring at the Light Beneficiaries are eligible costs if they are regarded as content-related and relevant investments for the implementation of the Light Projects. Detailed eligibility rules of expenditure are to be specified in the Application Pack.

Ineligible expenditure

As regard to ineligible expenditures, detailed rules are to be specified in the Application Pack.

Revenues generated by the projects

Light Projects are exempted from any deduction of revenues generated related to the Light Projects, as grants received by Light Projects are de minimis grants.

7. Project selection and evaluation system of Light Projects

7.1. Role of the two-step selection system

Light Project Proposals are selected through a two-step selection system via open Call for Proposals and are evaluated against the pre-defined set of criteria included in the Application Pack.

Rationale behind the two-step selection system:

- 1st selection step should focus exclusively on the content-related aspects of Light Concepts submitted by cooperating SMEs without serious administrative requirements to be met at this stage. This avoids SMEs from unnecessary project development efforts before evaluating their project concepts thematically.
- Main function of 1st step is selection of Light Concepts for further project development. Pre-selection of Light Concepts makes it possible to provide project development technical assistance for a pre-selected limited number of Light Concepts by External Project Support Facility (EPSF) to develop their Light Project ideas to Light Project Proposals. EPSF technical assistance falls under state aid should be regarded as de minimis grant (see Chapter 4.1.).
- Owing to the 1st step of selection, 2nd step of selection can be made on a pre-selected and EPSF assisted, matured Light Project Proposals. This improves quality orientation of selection mechanism resulting in high-value added and innovative cooperation projects.

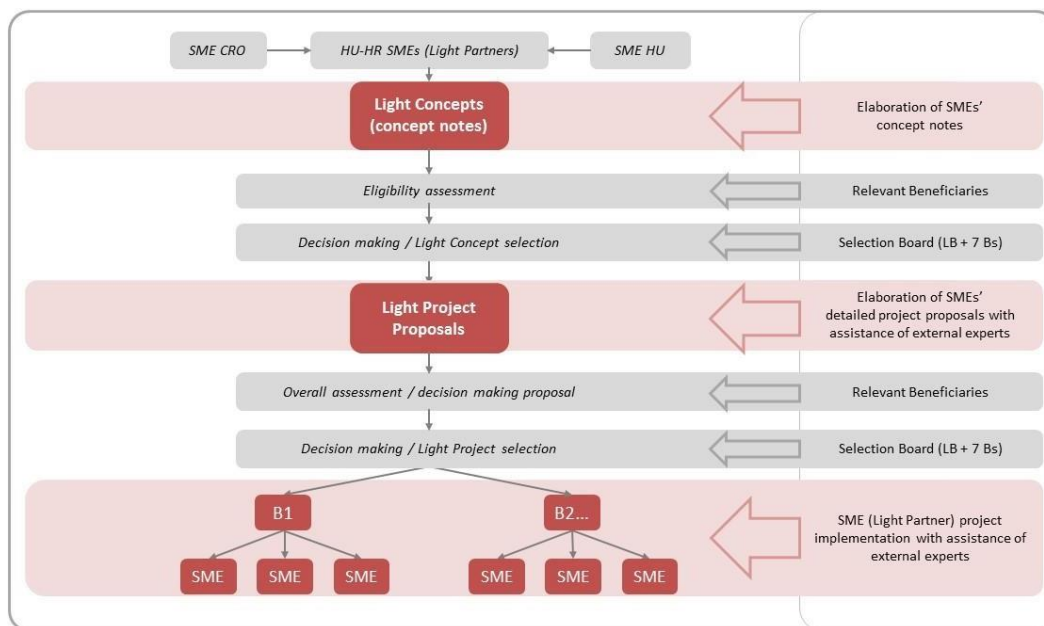

Figure 4: Two-step project selection system of B Light Scheme.

7.2. Selection Board

The Scheme's main decision-making body is the Selection Board (SB). The SB is responsible to make selection of both the Light Concepts and the Light Project Proposals. The SB is composed of 8 members, 1-1 members delegated by the LB and each of the 7 Bs.

Decisions in the SB are made with majority voting, however selection of the Light Concepts and Light Project Proposals require the unanimous positive decision of the delegates of the territorially competent Bs.

The LB has block voting rights in terms of administrative and financial issues.

From programme level bodies, the MA, NA and the JS are invited as non-voting members, however the MA shall have the right of veto if a decision made by the SB would threaten the overall due performance of the cross-border cooperation programme.

7.3. 1st selection step: Light Concepts (Concept notes)

Preparation of Light Concepts is supported by the Beneficiaries by the following project generation activities:

- Active promotion of B Light Scheme among SMEs operating in the programme area.
- Providing first level information to SMEs interested in B Light Scheme, local consultations.
- Organisation of information events in all counties for promoting B Light Scheme.
- Organisation of brokerage events in the border region for establishing SME project cooperation.
- Running of the online B Light Platform for submission of Light Concepts and Light Project Proposals, event calendar and partner search facility for potential Light Beneficiaries.
- Launching 1st round Call for Light Concepts for cooperating SMEs.
- Evaluation of submitted Light Concepts.

Main content elements of Light Concepts (detailed specification is included in the Application Pack):

- title of the Light Project,
- short introduction of Light Beneficiaries (SMEs), their previous record;
- aim of cooperation: introduction of value-added cross-border joint technology, service and product development;
- pre-definition of Light Project indicators: estimation for the value of selling of commonly developed new or upgraded product, technology or services by all the Light Beneficiaries;
- list of proposed activities by Light Beneficiaries;
- indicative overall budget of proposed activities by Light Beneficiaries.

Light Concept is prepared jointly by cooperating SMEs. Required language of Light Concepts is either English.

Evaluation and decision on Light Concepts has the following process:

- Submission of Light Concepts after launching the Call for Light Concepts with submission deadlines defined by the Application Pack.

- Light Concepts are to be submitted by any of the involved Light Concept applicants through the B Light Platform operated by the LB. Format and administrative requirements of submission are defined by the Application Pack.
- As a general rule, Light Concepts are jointly evaluated by the regionally competent Beneficiaries: territorially competent Beneficiaries of all Light Beneficiaries fill in evaluation form on the Light Concept based on the evaluation grid included in the Application Pack. Staff involved in the evaluation phase from side of the Bs should be different from the persons involved in generation of the Light Concepts.
- If the score, for a single LC, between any two evaluators (Bs) significantly differs (by 7 or more points or in its conclusion), the LB might also decide to conduct an evaluation of the particular LC.
- Filled-in evaluation forms are circulated among the Lead Beneficiary and all 7 Beneficiaries.
- Within 60 days after submission deadline of Light Concepts a Selection Board session should be organised.
- Selected Light Concepts are appointed for further project development (no financial support is allocated to the Light Concepts at this stage).
- If one or more Light Partners withdraw from the partnership at any point of the application process, the LC will be ineligible for further development. In this case, Light Concept that is next on the Rank List of evaluated proposals should be recommended for further development.

7.4. 2nd selection step: Light Projects

Detailed elaboration of Light Projects is also coordinated by the Lead Beneficiary and the Beneficiaries by the following project generation activities:

- Launching 2nd round Call for Light Project Proposals for partners of the selected Light Concepts, with a fixed deadline defined by the Application Pack.
- Experts involved in the External Project Support Facility (EPSF) will assist Light Beneficiaries of the selected Light Concepts in preparing their detailed Light Project Proposals. Acceptance of EPSF technical assistance is a pre-requisite for entering the 2nd step of the application procedure of the B Light Scheme.

During this stage, the LB and the Bs supervise project development activities of the EPSF, organise information events for Light Beneficiary applicants for knowledge transfer and exchange of best practices of joint technology, service and product development.

Main content elements of Light Project Proposals (detailed specification to be included in the Application Pack):

- administrative data of Light Beneficiaries;
 - Light Project summary;
 - Introduction of Light Beneficiaries: their former and present activities, main markets of their products and services, export-import relations, human capacities;
 - description of Light Project: rationale of business cooperation of Light Beneficiaries, objectives in terms of value-added cross-border joint product, service or technology development, expected outputs, innovative character, sustainability of business cooperation, risk management, cross-border impact;
 - Competences of selling of Light Beneficiaries, places and predicted value of selling, business potential of jointly developed product, service or technology;
 - list of activities by Light Beneficiaries, description and timeframe of activities;
- definition of Light Project indicators, the most important ones: outlining contractual business agreement with third parties to be contracted in the sustainability period; target value of selling of commonly

developed new or upgraded product, service or technology by either or all of Light Beneficiaries within the sustainability period; contribution to the programme level indicator of increase of gross value added of Light Beneficiaries within the sustainability period;

- detailed budget of listed activities by Light Beneficiaries;
- sources of funding by Light Beneficiaries;
- payment forecast by reporting periods and by Light Beneficiaries;
- location of works activities and required permits;
- information and publicity activities;
- supplementary documentation in Annexes (documentary requirements laid down in the Application Pack).

Required language of Light Project Proposal is English.

Evaluation and decision on Light Project Proposals has the following process:

- There is a fixed submission deadline of Light Project Proposals – defined by the Call for Light Project Proposals.
- Light Project Proposals are submitted by any of the involved Light Project applicants through the B Light Platform operated by the LB. Format and administrative requirements of submission are defined by the Application Pack.
- Administrative compliance of Light Project Proposals should be examined by the Beneficiary to which the Light Project Proposal was submitted.
- The relevant Beneficiary judges administrative compliance of the submitted Light Project Proposal and either rejects or approves the proposal for further content-based evaluation. For incomplete Light Project Proposals Light Beneficiary applicants will be requested to deliver completion of missing documents until a given deadline.
- Beneficiary should inform the members of the Selection Board and also the Light Beneficiaries concerned about its decision on administrative compliance.
- Each Light Project Proposal receives three scores: one from the Lead Beneficiary, one from the Joint Secretariat and one from two Beneficiaries jointly, the latter have to be independent from the counties which have SME-s in the given LPP. The evaluators fill in evaluation form on the Light Project Proposals based on the evaluation grid included in the Application Pack. Staff involved in the evaluation phase from side of the Bs should be different from the persons involved in generation of the Light Concepts or any kind of involvement in the elaboration of the Light Project Proposal.
- The final score for a single LPP will be the mathematical average of the three scores awarded by the different evaluators. (The joint score awarded by the two Beneficiaries that are involved shall be the mathematical average of their own two scores.)
- Filled-in evaluation forms are circulated among the Lead Beneficiary and all 7 Beneficiaries.
- Lead Beneficiary should compile a summary of evaluation of Light Project Proposals for the given submission round based on the average scorings of each Selection Board members.
- Based on the average scorings and the grant allocation available for the given submission round Lead Beneficiary compiles a decision-making proposal to be submitted to the Selection Board.
- Within 60 calendar days after the respective cut-off date the LB will organise an SB meeting, however the postponement of the deadline is possible if the quality check of the evaluation or the appointment of new Evaluators is necessary.
- Based on the decision of the Selection Board Lead Beneficiary should sign Partnership Agreement with Light Beneficiaries of the granted Light Project.
- If one or more Light Partners withdraw from the partnership at any point of the application process, the LPP will be ineligible for financing. In this case, Light Project Proposal that is next on the Rank List of evaluated proposals should be recommended for financing.

7.5. Contracting

Regarding contracting, it needs to be emphasized that the whole B Light Scheme is a single project in the Cooperation Programme's administrative and legal logic. Therefore, one Subsidy Contract will be signed with the partnership as a whole, at the time when the B Light Scheme project proposal is approved for funding by the MC. The entering of the Light Beneficiaries in the Scheme does not change the Subsidy Contract, only the Partnership Agreement between the partners.

The procedure of contracting starts with the approval of the B Light Scheme project by the MC. After that, the process of contracting EU contribution is as follows:

- Based on the decision of the MC, the MA notifies in writing the Lead Beneficiary of the approval of the B Light Scheme project. The letter of approval contains the list of documents to be submitted for contracting, the conditions of the MA (if any) and the name and contact data of the programme manager responsible for the B Light Scheme project at the JS.
- If the project was approved with conditions, the responsible programme manager of the JS examines the documents submitted by the Lead Beneficiary in answer to the notification letter. If parts of the documentation requested in the notification letter are not properly submitted, a request for missing documents is issued and, if necessary, personal consultations and/or site visits, documented by the JS, are held in order to assure compliance with the conditions set by the MA and/or with the requirements relating to the documentation necessary for contracting.
- After the documents necessary for the drafting of the Subsidy Contract for the EU contribution have been properly submitted and examined, the responsible programme manager of the JS prepares and sends a note on the compliance of the documentation to the MA.
- Based on the project proposal, the conditions of the MA (if any) and on the documentation submitted by the Lead Beneficiary, the MA issues the declaration on commitment for the whole B Light Scheme project and the responsible programme manager of the JS prepares the Subsidy Contract for the EU contribution of the B Light Scheme project with the Partnership Agreement as Annex to the Subsidy Contract.
- Hereafter the draft Subsidy Contract for the EU contribution is made subject to quality assurance. The finalised Subsidy Contract for the EU contribution is copied and sent to the Head of the MA for signature. Then the Subsidy Contract is signed by the LB as well as the Partnership Agreement is signed by the LB and all the Bs as Annex to the Subsidy Contract.

When Light Beneficiaries of a Light Project enter the Scheme, the following contracting process for EU contribution is followed:

- The Partnership Agreement (PA) is modified by an Addendum to include the Light Beneficiaries, the information on the Light Project, the respective activities and outputs.
- The PA Addendum is signed by the LB and the newly entered Light Beneficiaries of the Light Project.
- The PA Addendum, together with the de minimis self-declarations from the Light Beneficiaries are sent to the JS (see Chapter 4.1.).
- The responsible programme manager of the JS prepares and sends a note on the compliance of the documentation to the MA and the funding automatically comes into effect.

8. Implementation and monitoring

8.1. Project duration

Duration of B Light Scheme project is set as 4,5 years after signature of Subsidy Contract.

The B Light Scheme project could be closed earlier if at least 80 pcs of Light Beneficiaries have implemented and successfully closed their Light Projects and the 2 years of sustainability period of all Light Projects has passed with reaching the indicators of all Light Projects successfully.

Duration of a single Light Project shall be between 6 and 18 months, **the period of implementation of project may not start before the date of the receipt of the Light Project Proposal by the LB but can start** after what should be indicated in the proposal together with the final date of the implementation period of the light project.

8.2. Reporting procedures

As the Scheme acts like any other projects financed by the Cooperation Programme, reporting requirements match those in case of projects in other priorities.

- Partner level reporting of the LB and the Beneficiaries

The LB and the Beneficiaries are obliged to deliver their partner level activity report in 10 days after closure of the project period (trimester) to the territorially competent FLC (see 2.4). The FLC has further 60 days to control, raise clarifications and issue the DoVE to the LB and the Beneficiaries. During the project implementation besides regular document-based checks the FLC may carry out on-the-spot checks (one time before project closure, but several other such checks may be applied) as well. Detailed rules of reporting will be laid down in the Implementation Pack.

- Partner level reporting of the Light Beneficiaries

As the Light Beneficiaries are to be considered as regular project partners having signed the Partnership Agreement, they are also required to report their activities and expenditures to the FLC. As the two-step reporting procedure and slow reimbursement – compared to mainstream funding mechanisms – would represent a considerable financing difficulty to the Light Beneficiary SMEs, reporting shall take place in four-month periods with faster procedures. The EPSF provides the Light Beneficiaries technical assistance in the reporting process. Besides document-based checks each Light Beneficiary has to undergo minimum one on-the-spot check before issuing the final DoVE.

Partner level control focuses on activities implemented by the Light Beneficiary in the project period and related expenditures occurred. Detailed guidelines, including the types of documents needed for proving the eligibility of cost items are to be included in the Implementation Pack and communicated to the Light Beneficiaries.

- Scheme level reporting

Payment of the EU co-financing is linked to submission and approval of regular progress reports. Reporting in case of the Scheme is also in line with the Lead Beneficiary principle. As the partnership is composed of Light Beneficiaries as well, reporting procedure should be speeded up in order to make four-month periods applicable

and avoid overlapping between the consecutive reporting periods. Submission and approval of the progress and final reports shall take place through the IMIS system.

The project level report is based on the verified costs declared in the DoVEs of the Beneficiaries and the Light Beneficiaries and detailed description shall be given on the implemented activities in the given period, including the achievement of relevant indicators. Content of the report has to be justified with the relevant evidences. In case of missing or unclear information the JS issues request for clarification. The JS has the right to ask for exceptional reports in between reporting periods and ask information on progress of the project in general at any time during the implementation.

In spending of the funds available for the Scheme is not carried out in line with the Scheme's payment forecast, the MA may ask interim progress reports. In case of severe deviation from the planned spending forecast, budget of the Scheme may be reduced, including the budget of the problematic Light Projects (decommitment rule – Article 76 of the CPR).

- Reporting on Selection (Selection Report)

After every selection round the LB is obliged to submit a detailed report on the whole project selection procedure. The report contains every step of the project selection starting with the received number of the project concepts and ends with the list of selected projects. The Selection Report should be submitted to the JS not later than 10 calendar days after the decision of the Selection Board. The JS in 5 calendar days send out the Selection Report to the members of the MC for information.

8.3. Payment of co-financing

Amount of co-financing of operations of Lead Beneficiary and 7 Beneficiaries and minimum and maximum amounts of co-financing of Light Projects are stipulated in the Application Pack.

Payment of the co-financing takes place upon approval of the Scheme's progress or final reports. Payment is carried out to the invoice of the LB. The LB is obliged to transfer the appropriate sum of co-financing to the Bs and the Light Beneficiaries.

Total co-financing rates of Project Partners are as follows:

- 100% of the total eligible costs in case of the LB and 7 Bs;
- maximum 75% of the total eligible costs in case of Light Beneficiaries.

Co-financing is provided by European Regional Development Funds of the European Union and may be complemented by national co-financing upon the decision of the Member States. In order to avoid any differences in the total co-financing rates between Hungarian and Croatian Bs and Light Beneficiaries, the above-mentioned total co-financing rates refer to all Hungarian and Croatian Project Partners in case of national co-financing will be provided by any of the Member States.

Taking into consideration the length of the two-level control, payment of co-financing may take place in approx. 120-150 days following the end of each reporting period.

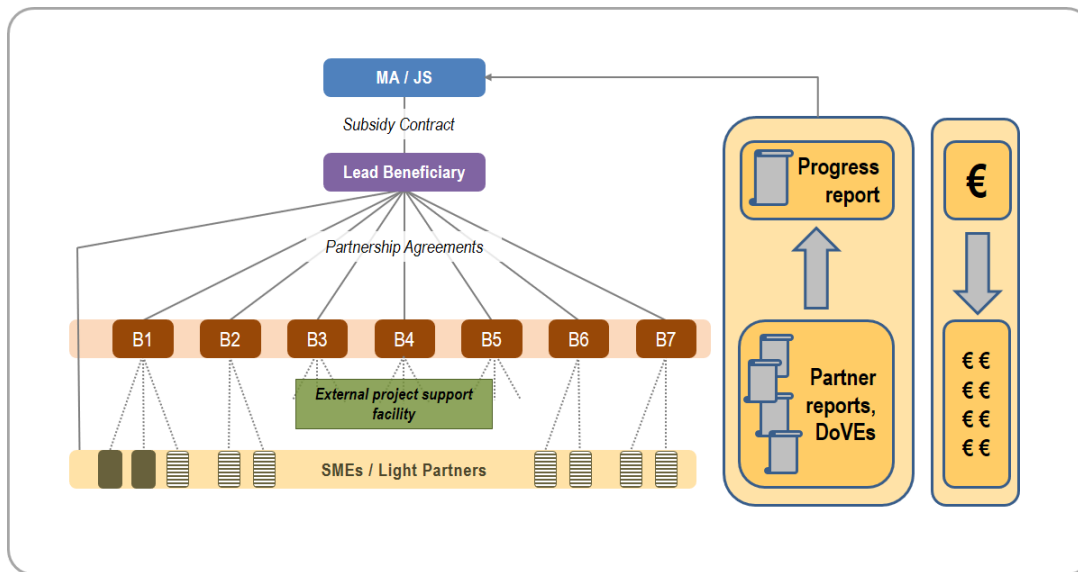

Figure 5: Flow of reporting and payment of co-financing.

8.4. Role of External Project Support Facility (EPSF) in management of Light Projects

Taking into consideration the complex administrative requirements of cross-border project management, technical assistance of External Project Support Facility (EPSF) is provided for Light Beneficiaries for coping with these requirements (see Chapter 2.3.). Lead Beneficiary has the role of appointing External Project Support Facility (EPSF) experts to the Light Beneficiaries of granted Light Projects. Acceptance of EPSF technical assistance is a pre-requisite of granting the Light Projects.

EPSF experts provide technical assistance to management of Light Project parts of Light Beneficiaries in the following fields:

- timing of Light Project activities to be implemented;
- checking of documents of expenditures of Light Beneficiaries;
- compilation of progress reports of Light Beneficiaries to the First Level Control;
- preparation for on-the-spot checks) done by the First Level Control or the JS;
- preparation of documentation in case of modification of LightProject.

EPSF does not take over the responsibility of Light Project management from Light Beneficiaries but Lead Beneficiary supervises its activity in light of successfulness of Light Project implementation.

8.5. Procurement rules

According to Regulation (EU, Euratom) No 966/2012 of the European Parliament and of the Council of 25 October 2012 on the financial rules applicable to the general budget of the Union and repealing Council Regulation (EC, Euratom) No 1605/2002, and based on other regulations relevant to the Cooperation

Programme, each contracted project has to manage procurements of services, supplies / goods / equipment and works in accordance with national procurement rules in force, depending on the seat and operational area of the given organisation (in Hungarian: Közbeszerzési törvény, in Croatian: Zakon o javnoj nabavi).

This means that the public procurement rules have to be applied also in the B Light Scheme, for all Project Partners, also including Light Beneficiaries.

In case of procurements that are not subject to public procurement (e.g. below the financial threshold for public procurement), but the value of the procurement reaches EUR 5,000 (excluding VAT), the Project Partners – also including Light Beneficiaries – are required to ensure three reference prices principle. Three reference prices principle means that Light Beneficiaries must obtain minimum three references which may be one, or combination, of the following:

- Offers within procurement procedure
- Pro-forma offers
- Reference price through Internet price-list or using centralised e-procurement services
- Other, as appropriate.

Under the value of EUR 5,000 (excluding VAT) no procurement procedure is required.

8.6. Obligations of the Project Partners

The Lead Beneficiary bears responsibility for the activities of the 7 Beneficiaries and all Light Beneficiaries and the sub-contractors like its own activities.

The Lead Beneficiary takes full responsibility for the damages caused to third parties from its own fault during the implementation of the operation. The Managing Authority has no responsibility for the damages caused to third parties as a result of executing the Subsidy Contract.

The Lead Beneficiary is liable towards the Managing Authority for ensuring that the Project Partners (7 Beneficiaries and all Light Beneficiaries) fulfil their obligations under the B Light Scheme.

If the irregularity is committed by any of the Project Partners, the concerned organisation shall repay to the Lead Beneficiary the amounts unduly paid. When amounts unduly paid to a Beneficiary cannot be recovered, due to negligence of the Lead Beneficiary, the Lead Beneficiary shall remain responsible for the repayment.

Glossary

Lead Beneficiary (LB): HAMAG BICRO, bears responsibility for overall coordination of the implementation of the Scheme, in line with the Subsidy Contract signed with the MA (see Chapter 2.2.).

Beneficiaries (Bs): the 7 county level SME development agencies responsible for coordinating the project activities in their respective counties (see Chapter 2.2.).

Project Partners (PPs): the LB and the 7 Bs of B Light Scheme project.

Light Beneficiaries ("B Lights"): SMEs taking part in a Light Concept and SMEs taking part in a Light Project Proposal submitted to the respective Call for Proposals and SMEs as Project Partners (final beneficiaries) of B

Light Scheme project. Light Beneficiaries can also be referred to as “*B Lights*”.

Light Concept: project concept note submitted by cooperating SMEs for the 1st step of the B Light Scheme Call for Proposal.

Light Project Proposal: project proposal submitted by cooperating SMEs for the 2nd step of the B Light Scheme Call for Proposal.

Light Project: project part of the B Light Scheme project granted through a two-step selection procedure, comprising eligible activities of cooperating Light Beneficiaries.

Subsidy Contract: Contract signed by the Lead Beneficiary and the Managing Authority for implementation of B Light Scheme project implemented under Priority 1 of Interreg V-A Hungary-Croatia Co-operation Programme 2014-2020.

Guidelines for Applicants: Guidelines for Applicants of the Interreg V-A Hungary-Croatia Co-operation Programme 2014-2020 for the First Call for Proposals launched on 29 February 2016, Approved by MC decision No 4/2016 (05.02).

Application Pack: consists of the Guidelines for Light Beneficiaries, the 1st step B Light Scheme Call for Proposal (Call for Light Concepts, Light Concept Form) and the 2nd step B Light Scheme Call for Proposal (Call for Light Project Proposals, Light Project Proposal Form).

Implementation Pack: consists of the Implementation Handbook for the Lead Beneficiary and the Beneficiaries and the Implementation Handbook for the Light Beneficiaries.

ANNEX I.

26.10.2012

EN

Official Journal of the European Union

C 326/333

ANNEX I

LIST REFERRED TO IN ARTICLE 38 OF THE TREATY ON THE FUNCTIONING OF THE EUROPEAN UNION

(1) No in the Brussels nomenclature	(2) Description of products
Chapter 1	Live animals
Chapter 2	Meat and edible meat offal
Chapter 3	Fish, crustaceans and molluscs
Chapter 4	Dairy produce; birds' eggs; natural honey
Chapter 5	
05.04	Guts, bladders and stomachs of animals (other than fish), whole and pieces thereof
05.15	Animal products not elsewhere specified or included; dead animals of Chapter 1 or Chapter 3, unfit for human consumption
Chapter 6	Live trees and other plants; bulbs, roots and the like; cut flowers and ornamental foliage
Chapter 7	Edible vegetables and certain roots and tubers
Chapter 8	Edible fruit and nuts; peel of melons or citrus fruit
Chapter 9	Coffee, tea and spices, excluding maté (heading No 09.03)
Chapter 10	Cereals
Chapter 11	Products of the milling industry; malt and starches; gluten; inulin
Chapter 12	Oil seeds and oleaginous fruit; miscellaneous grains, seeds and fruit; industrial and medical plants; straw and fodder
Chapter 13	
ex 13.03	Pectin
Chapter 15	
15.01	Lard and other rendered pig fat; rendered poultry fat
15.02	Unrendered fats of bovine cattle, sheep or goats; tallow (including 'premier jus') produced from those fats
15.03	Lard stearin, oleostearin and tallow stearin; lard oil, oleo-oil and tallow oil, not emulsified or mixed or prepared in any way
15.04	Fats and oil, of fish and marine mammals, whether or not refined
15.07	Fixed vegetable oils, fluid or solid, crude, refined or purified
15.12	Animal or vegetable fats and oils, hydrogenated, whether or not refined, but not further prepared

(1) No in the Brussels nomenclature	(2) Description of products
15.13	Margarine, imitation lard and other prepared edible fats
15.17	Residues resulting from the treatment of fatty substances or animal or vegetable waxes
Chapter 16	Preparations of meat, of fish, of crustaceans or molluscs
Chapter 17	
17.01	Beet sugar and cane sugar, solid
17.02	Other sugars; sugar syrups; artificial honey (whether or not mixed with natural honey); caramel
17.03	Molasses, whether or not decolourised
17.05 (*)	Flavoured or coloured sugars, syrups and molasses (including vanilla sugar or vanillin), with the exception of fruit juice containing added sugar in any proportion
Chapter 18	
18.01	Cocoa beans, whole or broken, raw or roasted
18.02	Cocoa shells, husks, skins and waste
Chapter 20	Preparations of vegetables, fruit or other parts of plants
Chapter 22	
22.04	Grape must, in fermentation or with fermentation arrested otherwise than by the addition of alcohol
22.05	Wine of fresh grapes; grape must with fermentation arrested by the addition of alcohol
22.07	Other fermented beverages (for example, cider, perry and mead)
ex 22.08 (*) ex 22.09 (*)	Ethyl alcohol or neutral spirits, whether or not denatured, of any strength, obtained from agricultural products listed in Annex I, excluding liqueurs and other spirituous beverages and compound alcoholic preparations (known as 'concentrated extracts') for the manufacture of beverages
22.10 (*)	Vinegar and substitutes for vinegar
Chapter 23	Residues and waste from the food industries; prepared animal fodder
Chapter 24	
24.01	Unmanufactured tobacco, tobacco refuse
Chapter 45	
45.01	Natural cork, unworked, crushed, granulated or ground; waste cork

(1) No in the Brussels nomenclature	(2) Description of products
Chapter 54	
54.01	Flax, raw or processed but not spun; flax tow and waste (including pulled or gametted rags)
Chapter 57	
57.01	True hemp (<i>Cannabis sativa</i>), raw or processed but not spun; tow and waste of true hemp (including pulled or gametted rags or ropes)

(*) Entry added by Article 1 of Regulation No 7a of the Council of the European Economic Community of 18 December 1959 (OJ No 7, 30.1.1961, p. 71/61).